

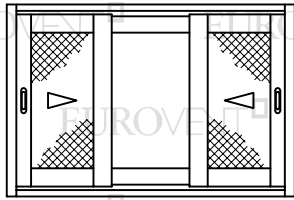

X X

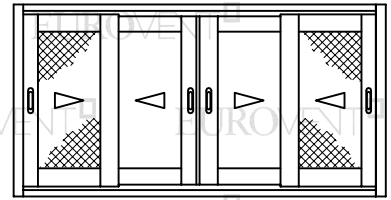

X O X



X X X X

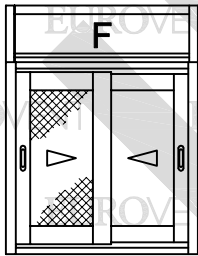

X X

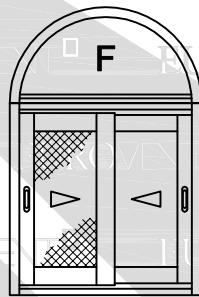

X X

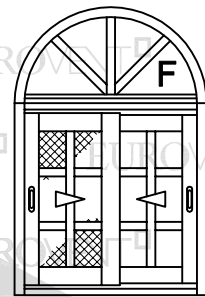

X X

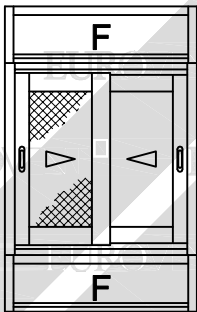

X X

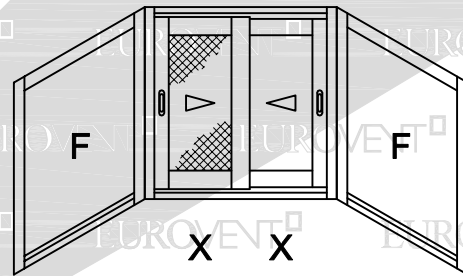

X X

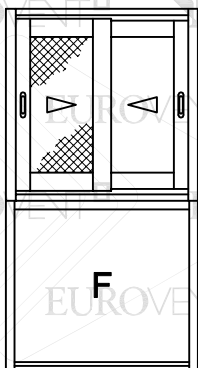

F

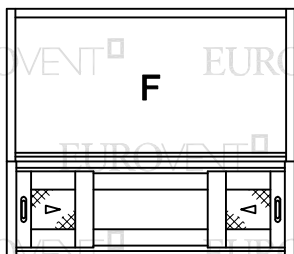

X O X

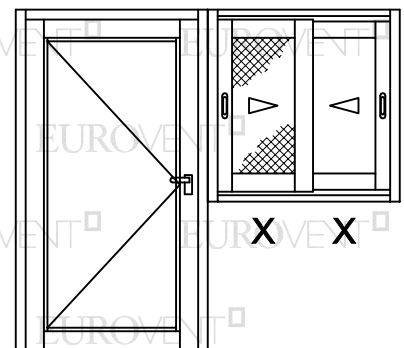

X X



CLASSIC

SERIE

S50



CORREDIZA

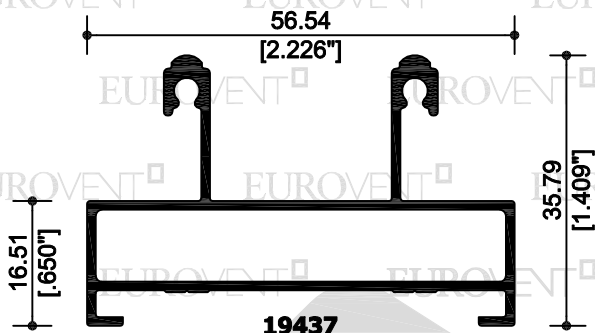

**19437**  
RIEL - CABEZAL

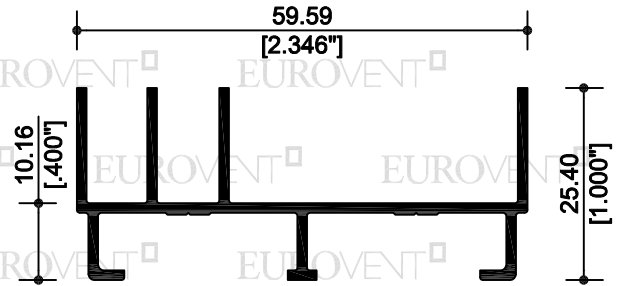

**19438**  
JAMBA

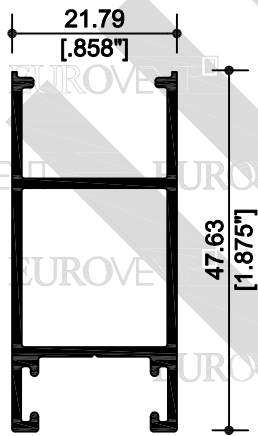

**19442**  
CERCO

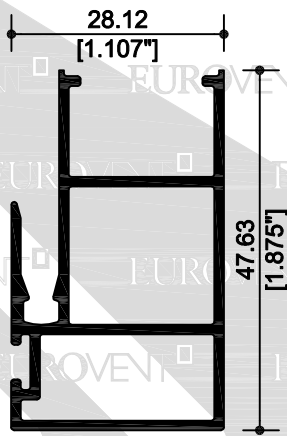

**19443**  
TRASLAPE

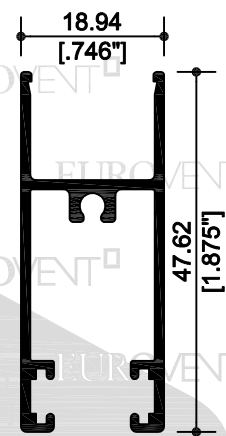

**19444**  
ZOCLO - CABEZAL

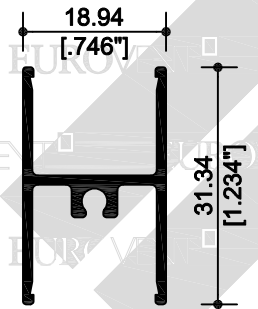

**19973**  
INTERMEDIO

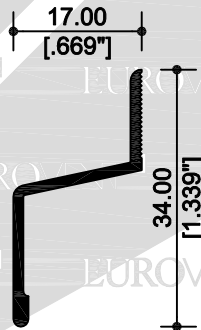

**12428**  
BOTAGUAS

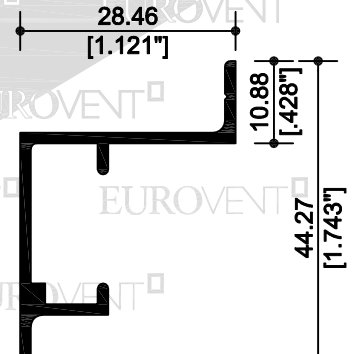

**11409**  
CABEZAL  
P/MOSQUITERO

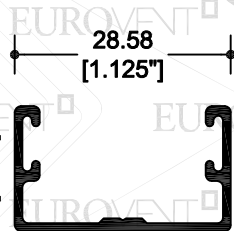

**19948**  
GUÍA INFERIOR

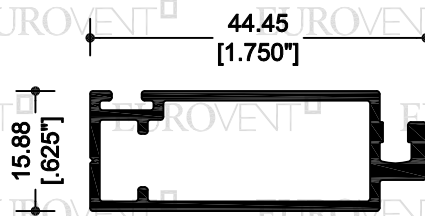

**18930**  
MOSQUITERO

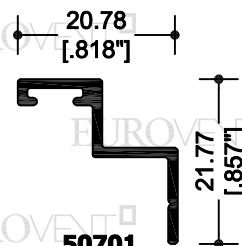

**50701**  
ADAPTADOR  
OXO



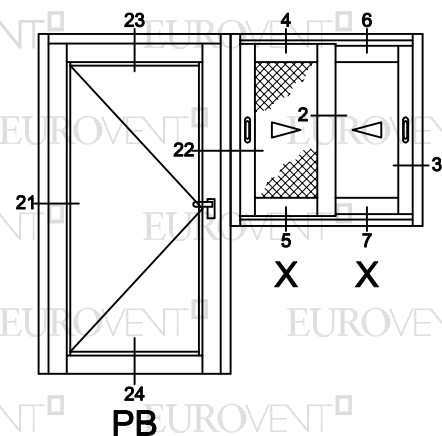
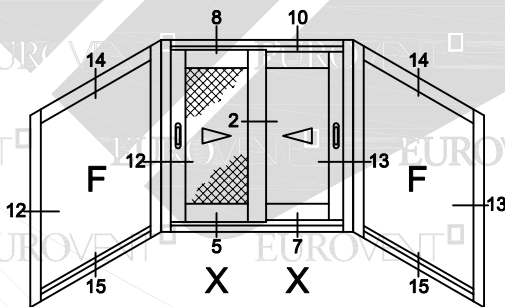
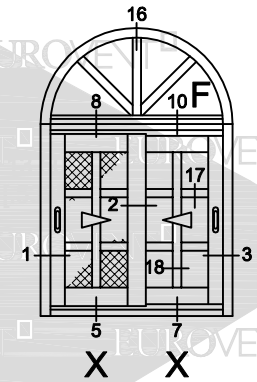
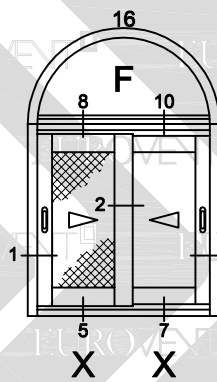
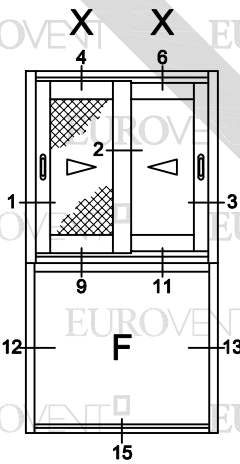
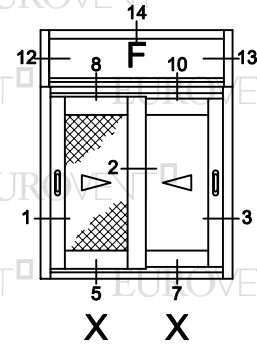
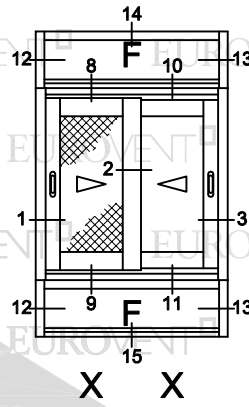
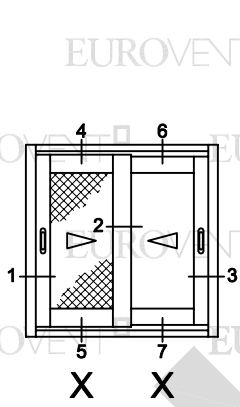

CLASSIC  
SERIE  
**S50**  
CORREDIZA

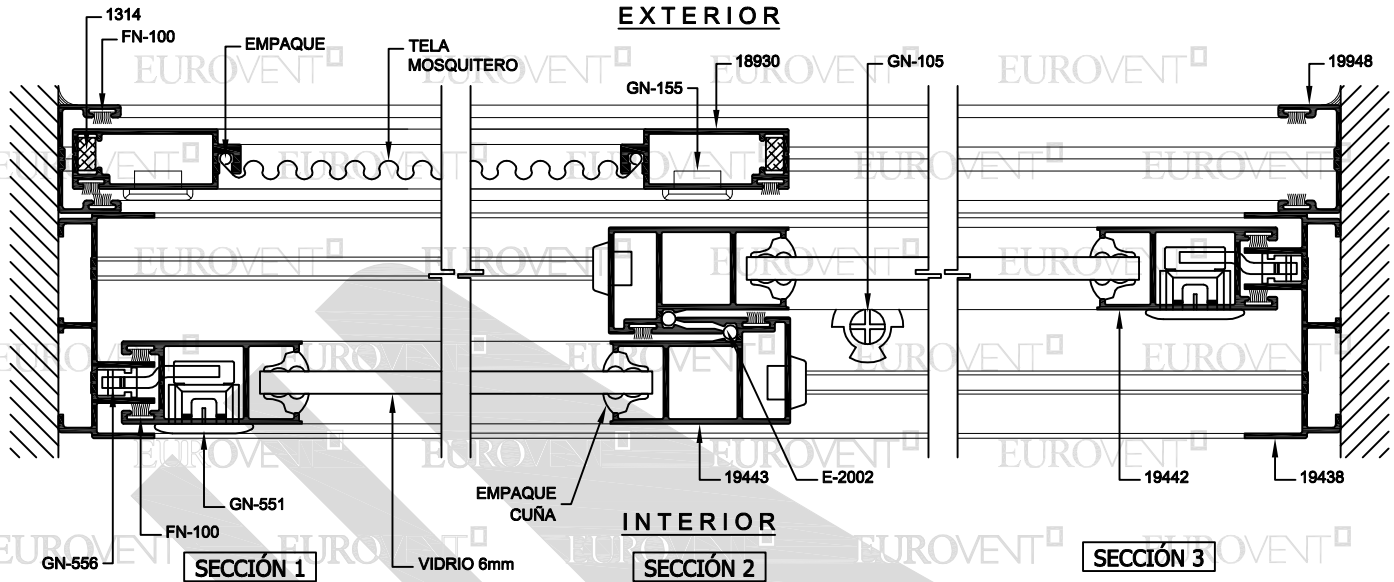

CLASSIC  
SERIE  
**S50**  
CORREDIZA

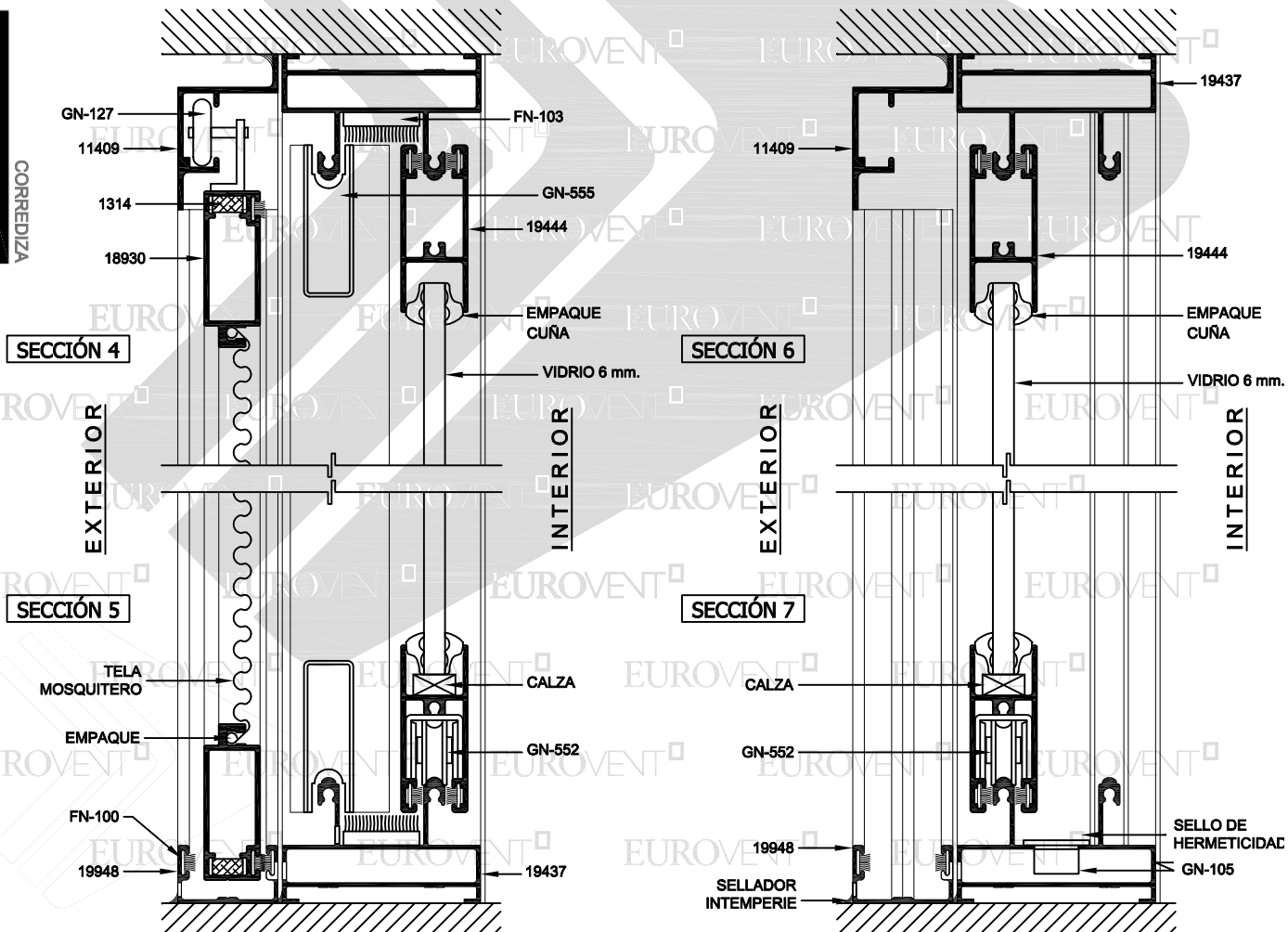

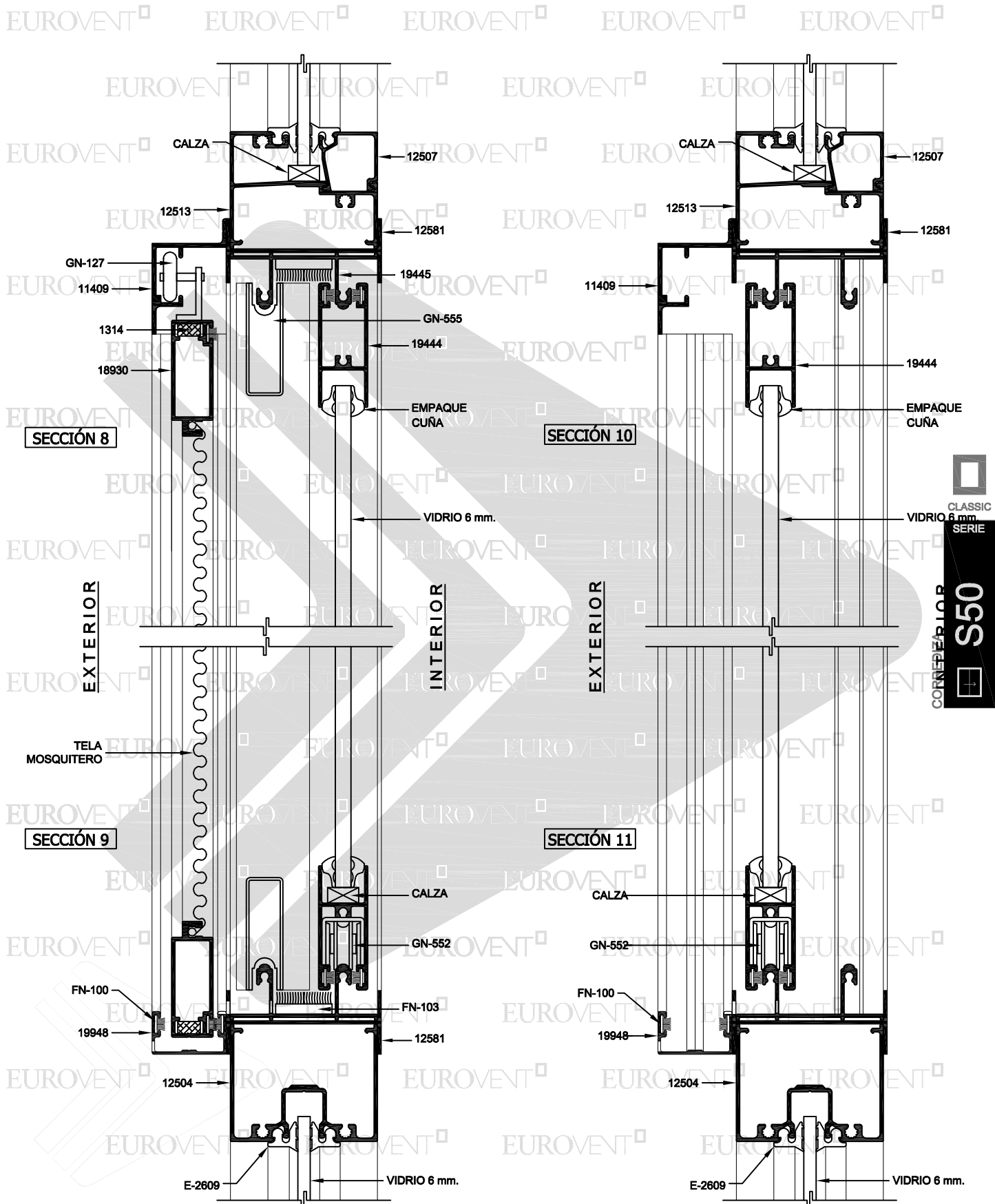

CLASSIC  
VIDRIO 6 mm.  
SERIE  
**50**  
CORREDIZAS

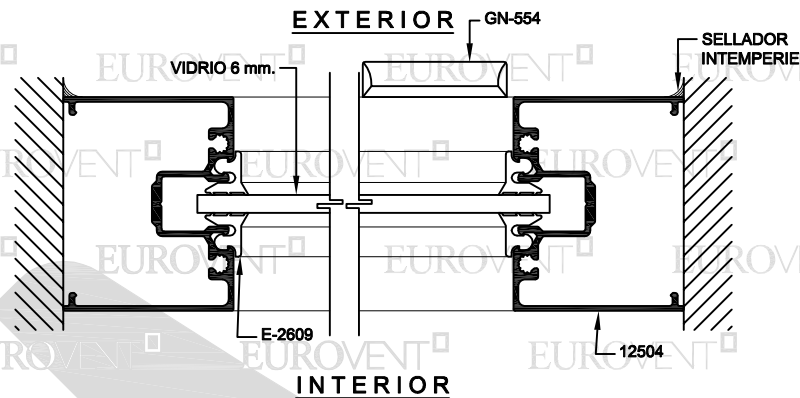

SECCIÓN 12

SECCIÓN 13

CLASSIC  
SERIE  
**S50**  
CORREDIZA

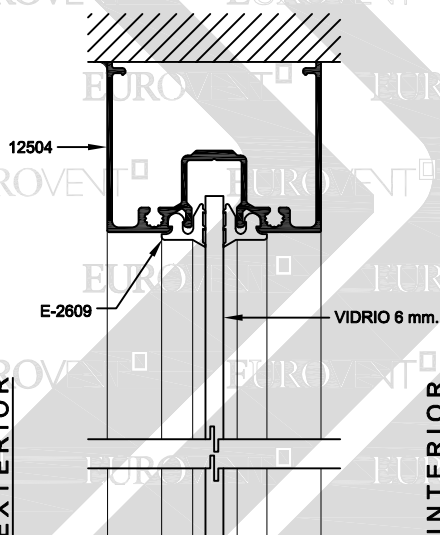

SECCIÓN 14

EXTERIOR

INTERIOR

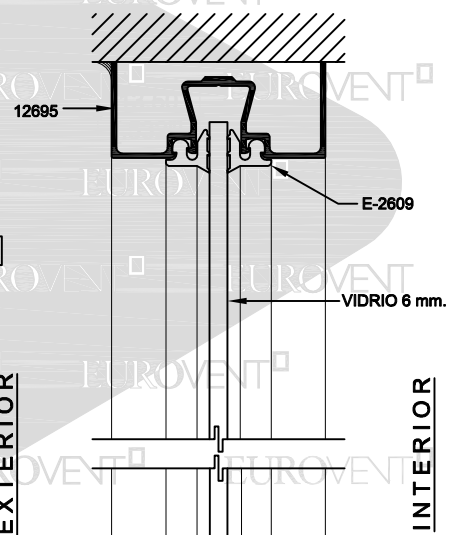

SECCIÓN 16

EXTERIOR

INTERIOR

SECCIÓN 15  
OPCIÓN

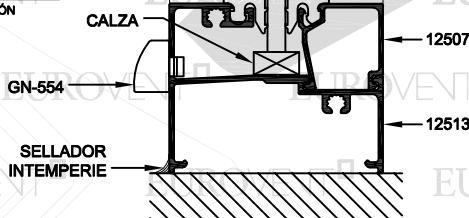

SECCIÓN 15  
OPCIÓN

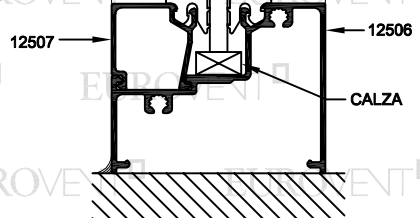

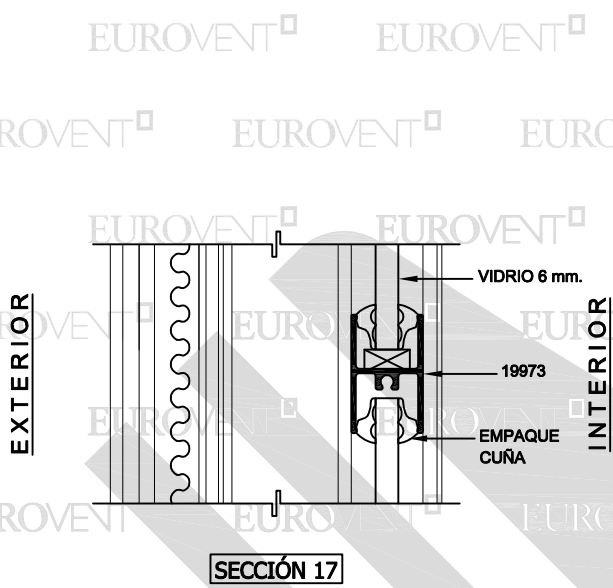

SECCIÓN 17

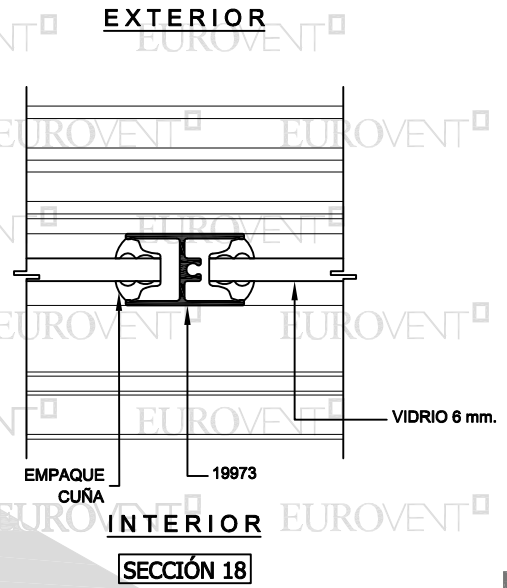

SECCIÓN 18

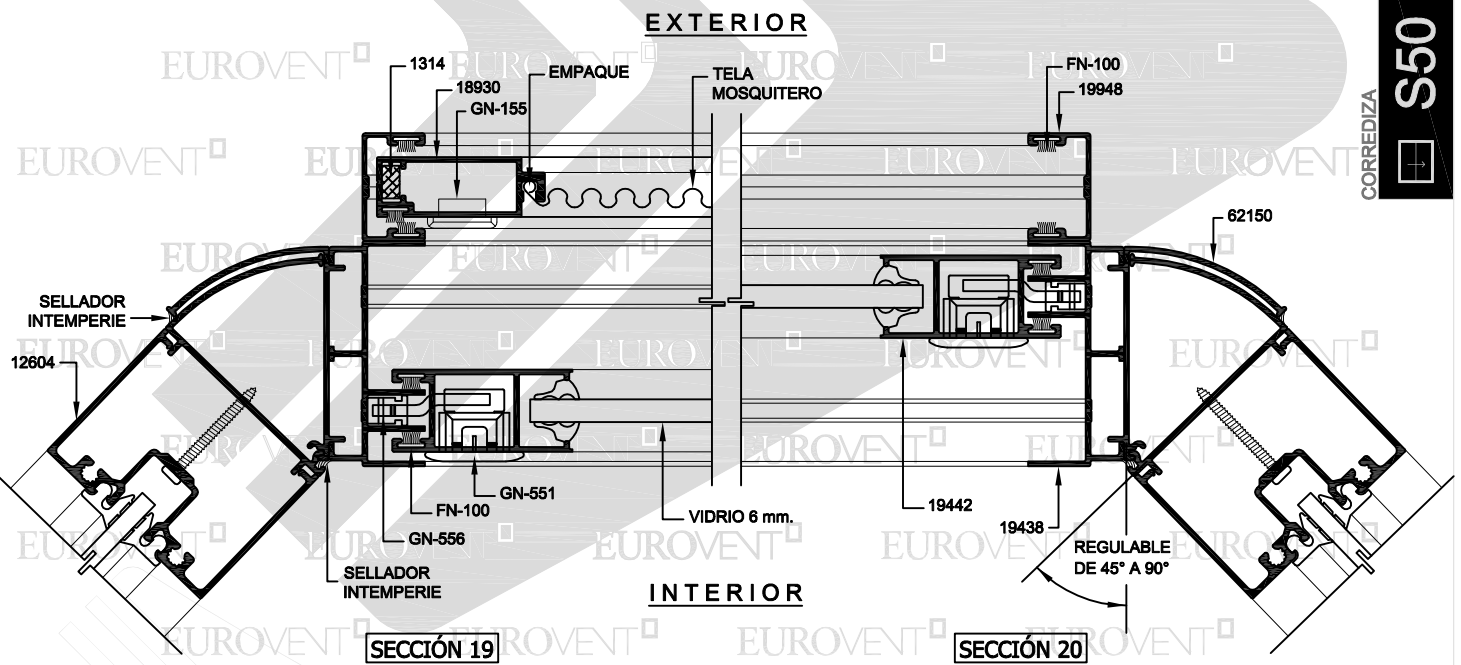

SECCIÓN 19

SECCIÓN 20

CLASSIC  
SERIE  
**S50**  
CORREDIZA

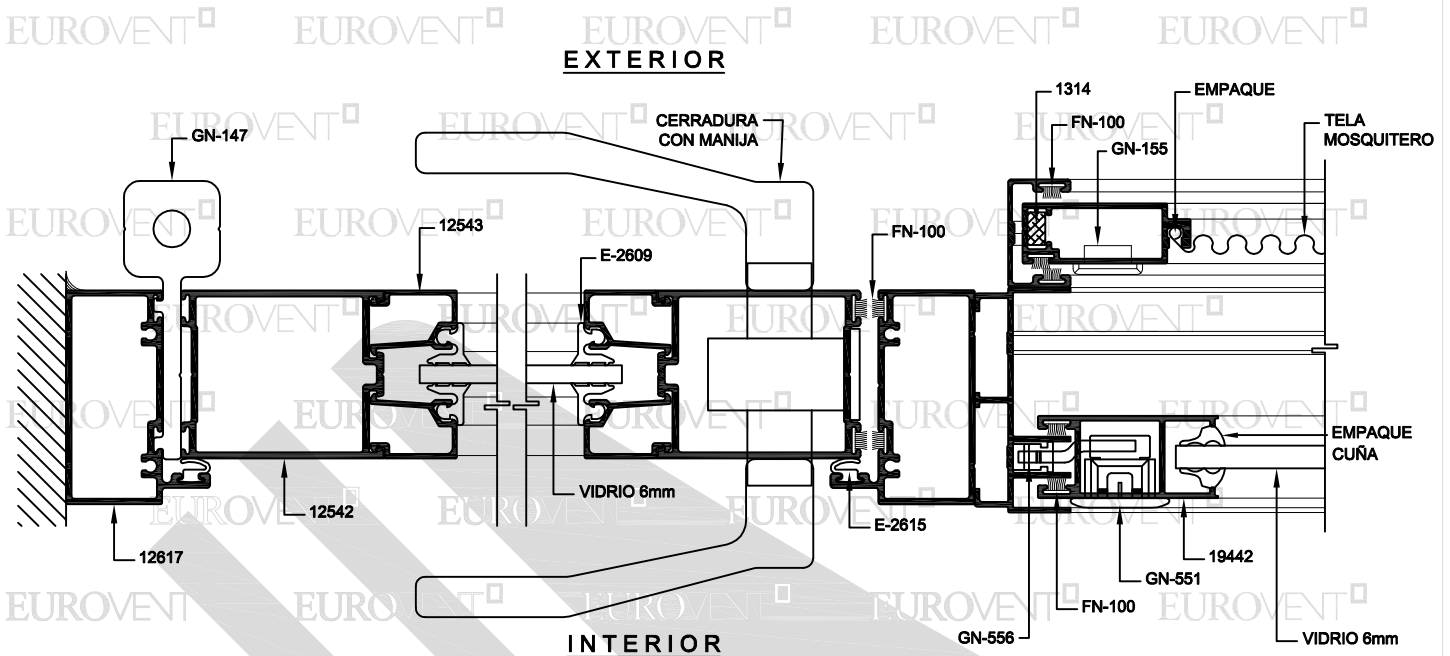

CLASSIC  
SERIE  
**S50**  
CORREDIZA

SECCIÓN 21

SECCIÓN 22

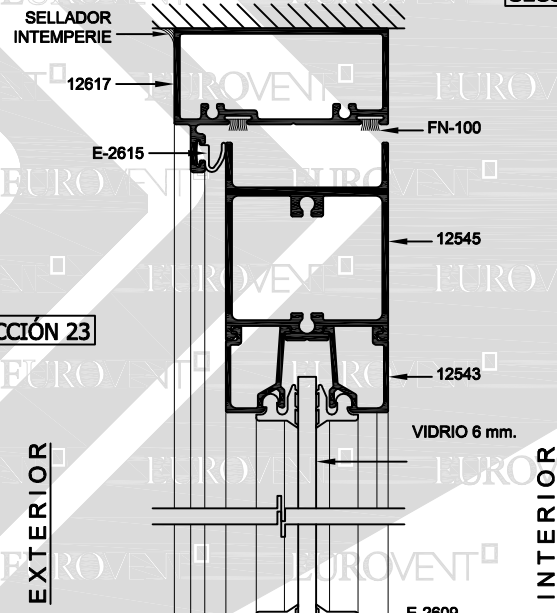

SECCIÓN 23

SECCIÓN 24

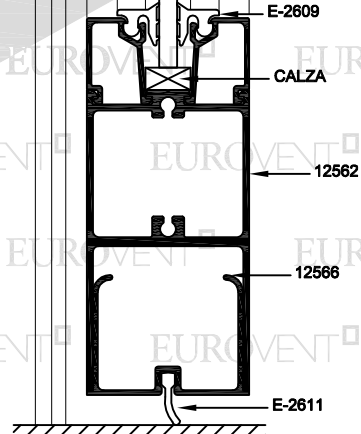



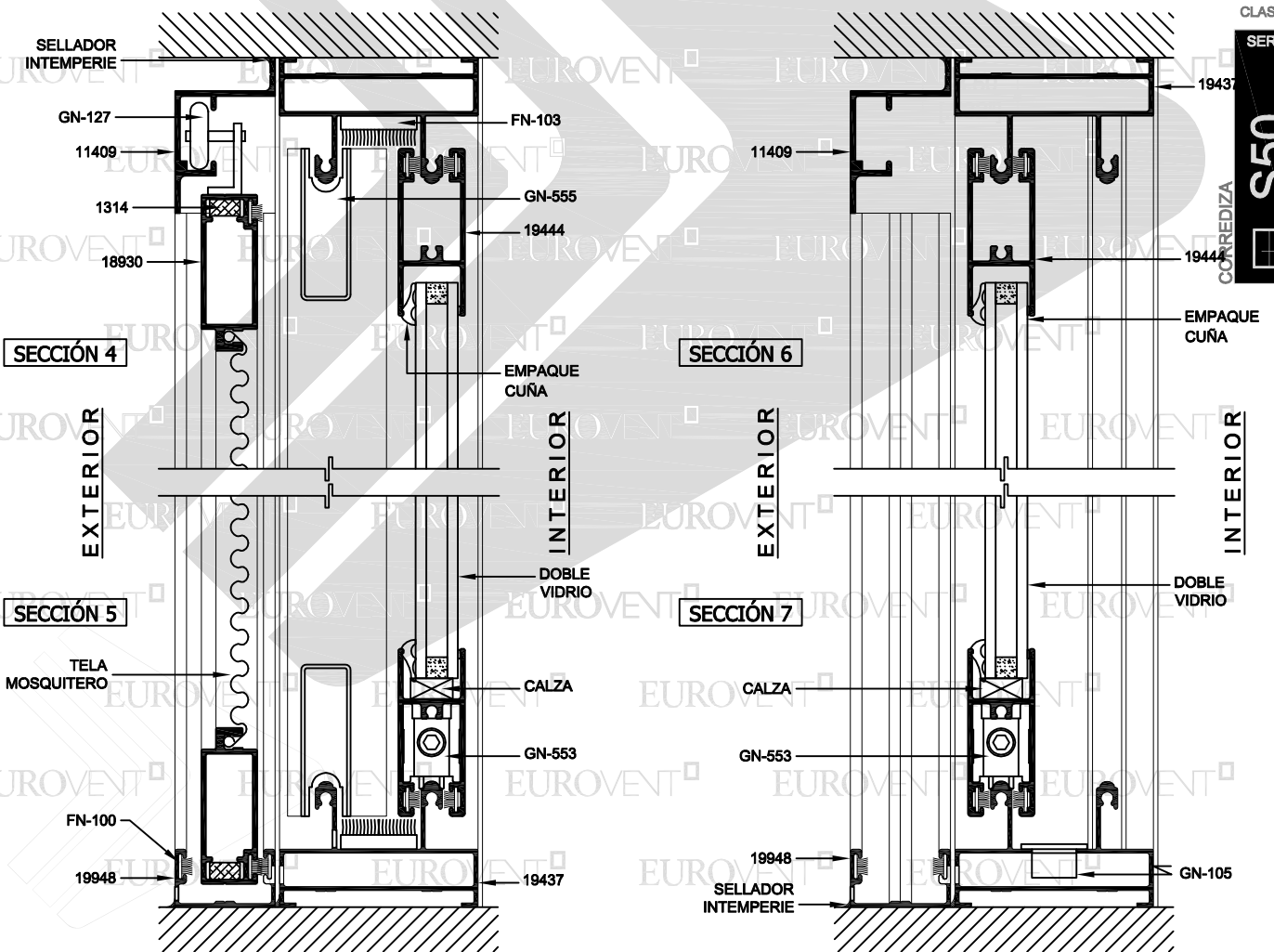
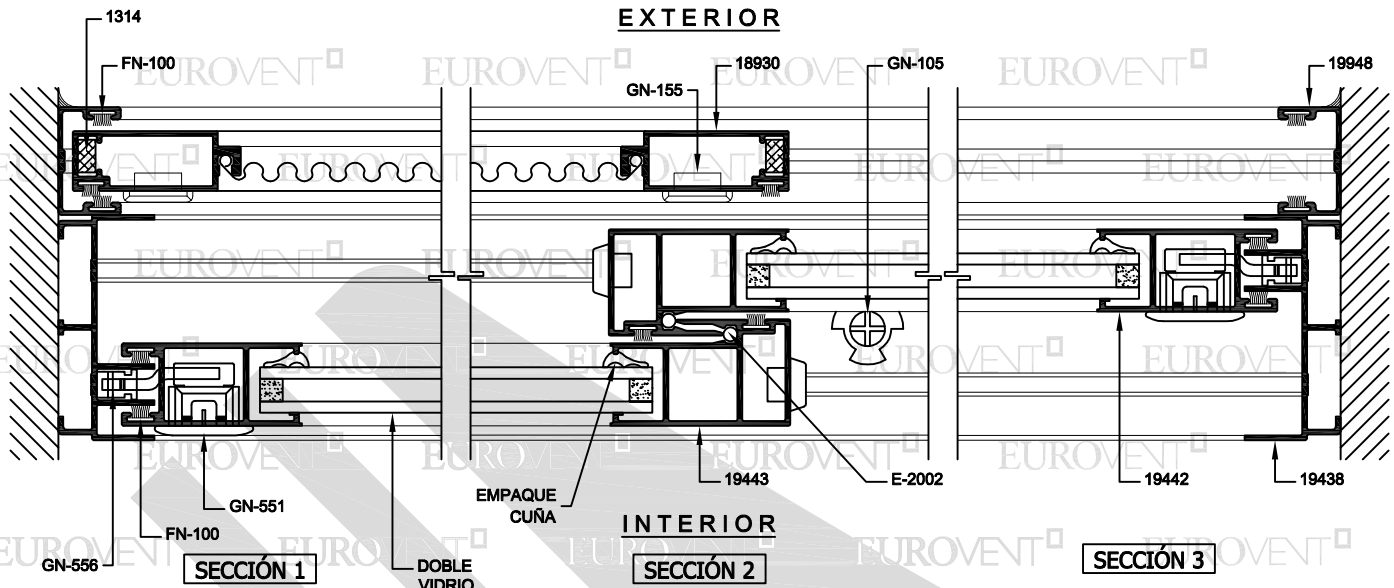

CLASSIC  
SERIE  
**S50**  
CORREDIZA

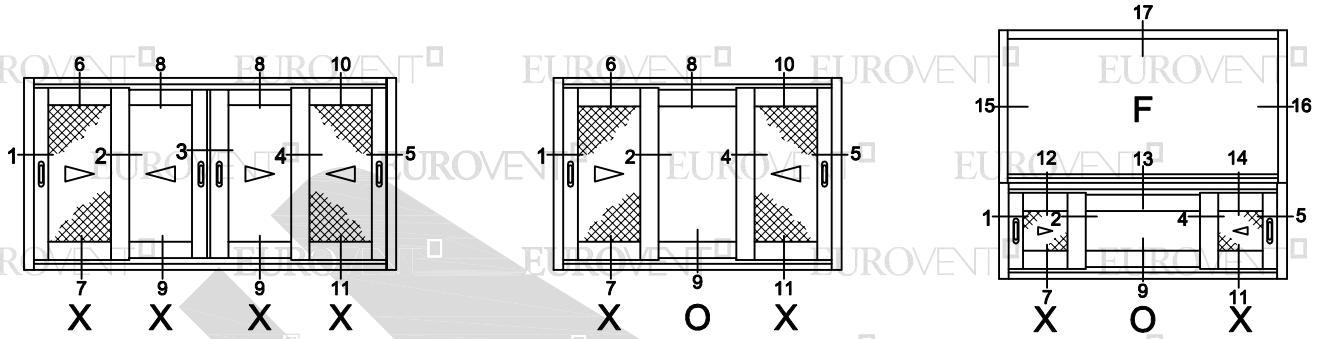

ELEVACIONES TIPO

SIN ESCALA

CLASSIC  
SERIE  
**S50**  
CORREDIZA

EXTERIOR

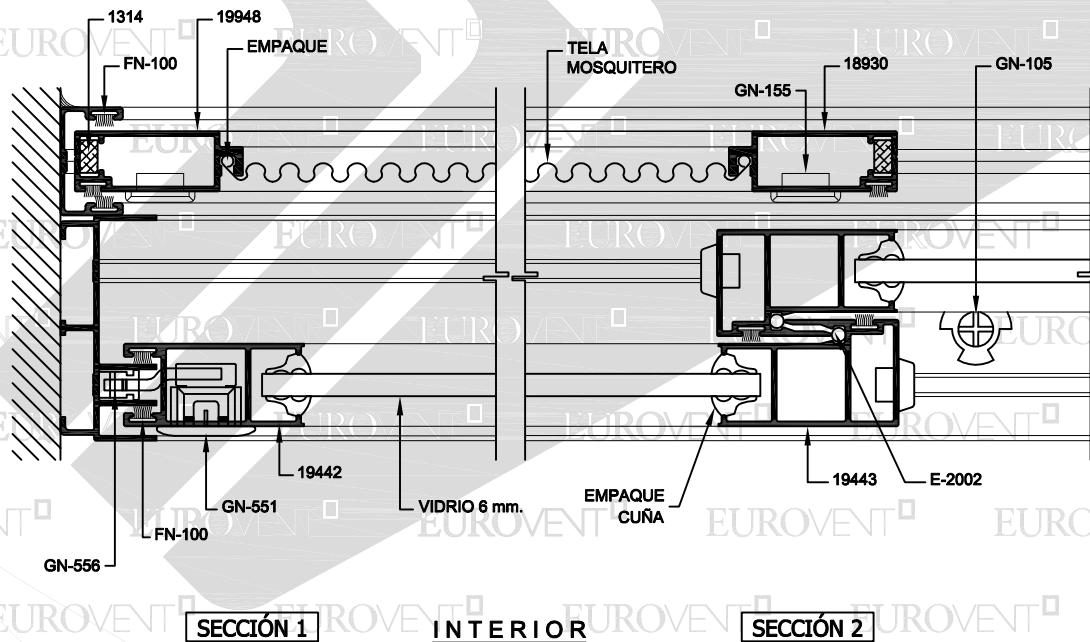

EXTERIOR

INTERIOR

SECCIÓN 3

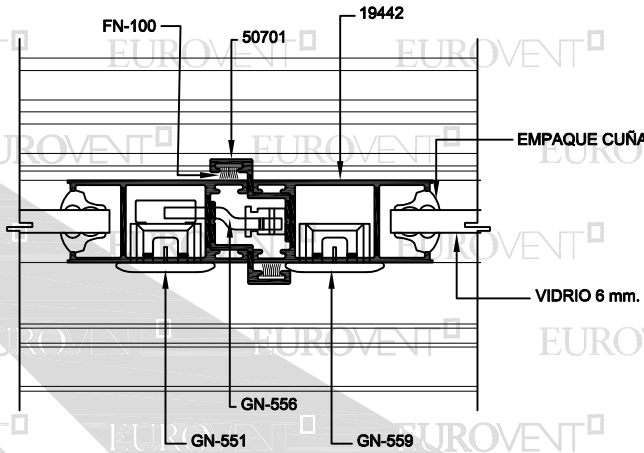

EXTERIOR

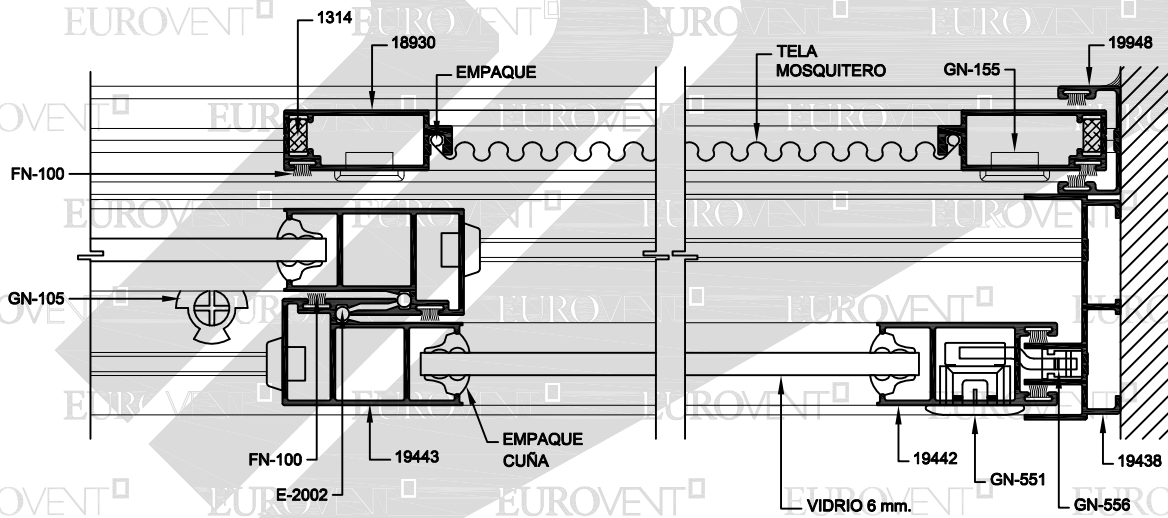

SECCIÓN 4

INTERIOR

SECCIÓN 5



CLASSIC

SERIE

S50

CORREDIZA



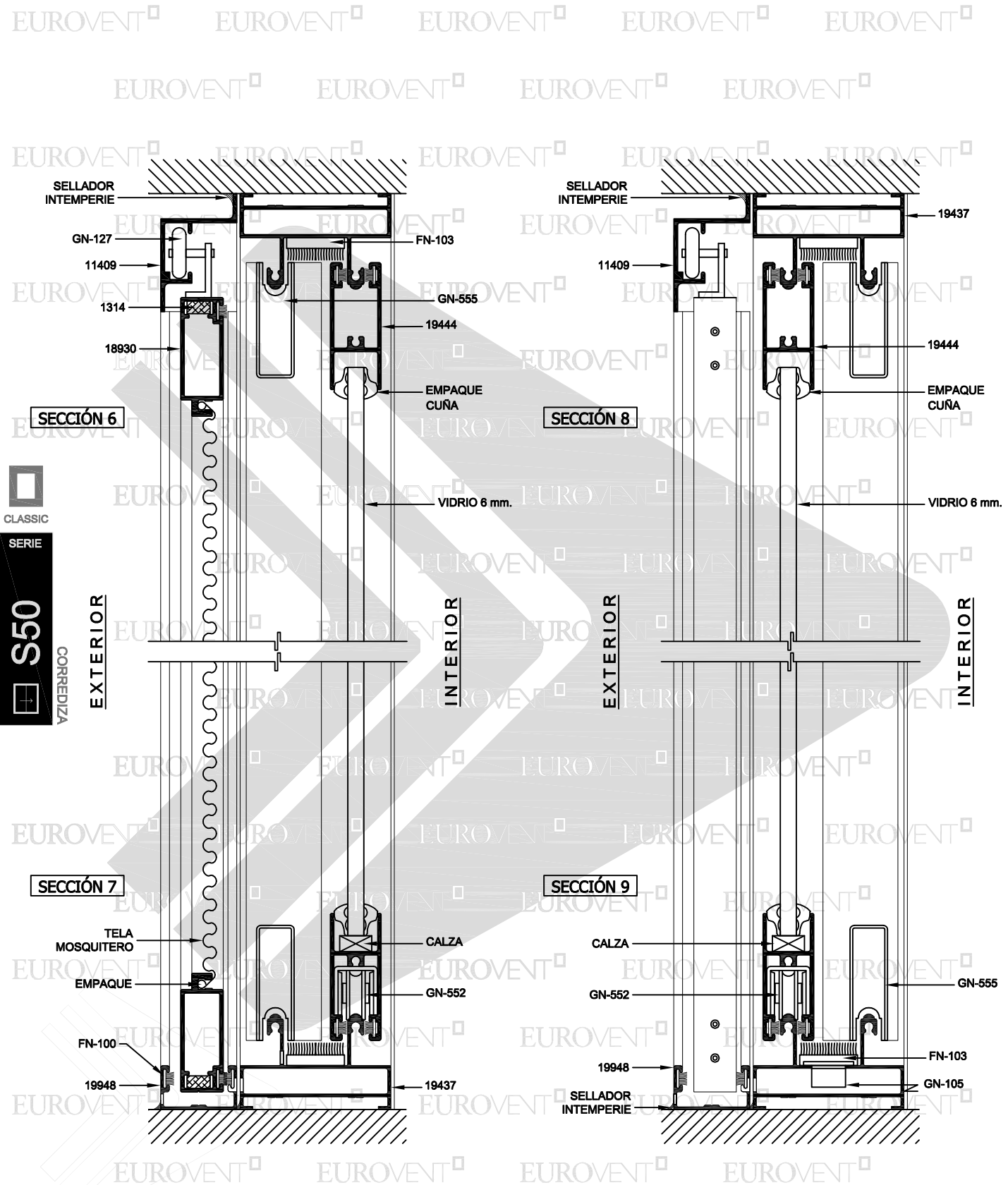

CLASSIC  
SERIE  
**S50**  
CORREDIZA

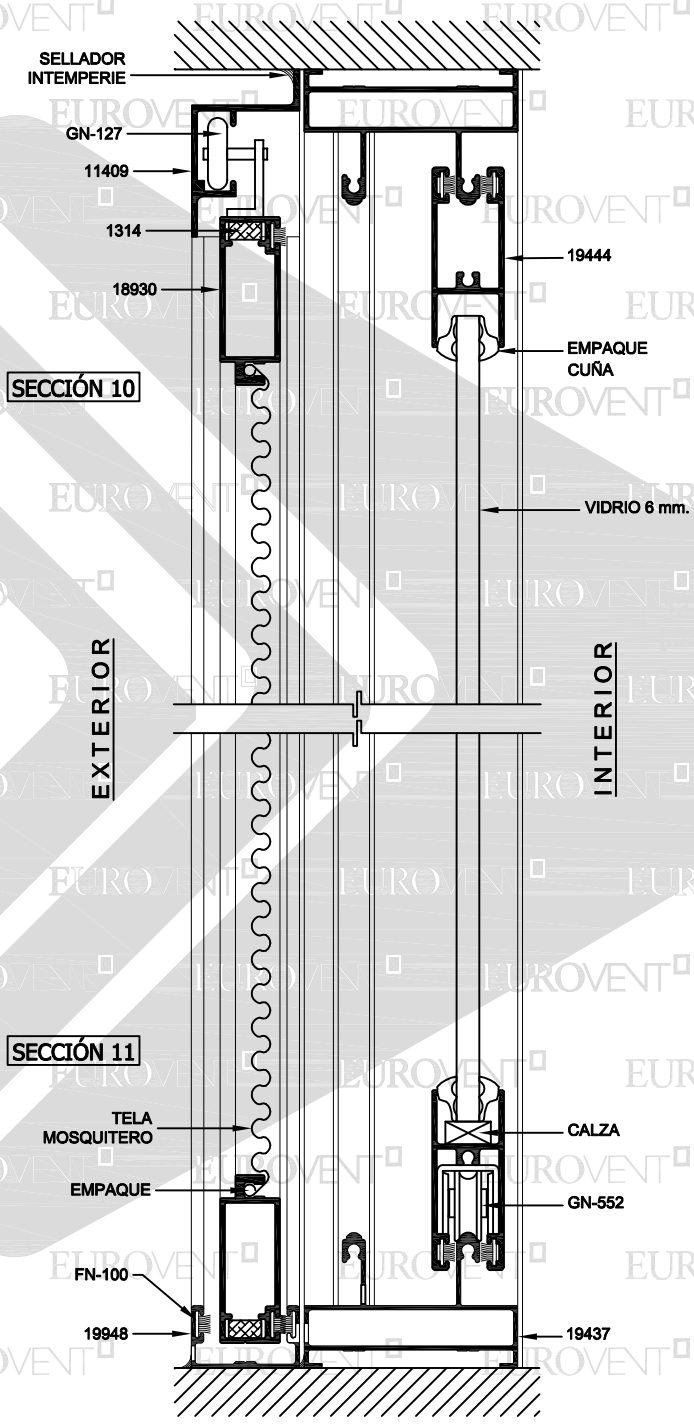

CLASSIC  
SERIE  
**S50**  
CORREDIZA

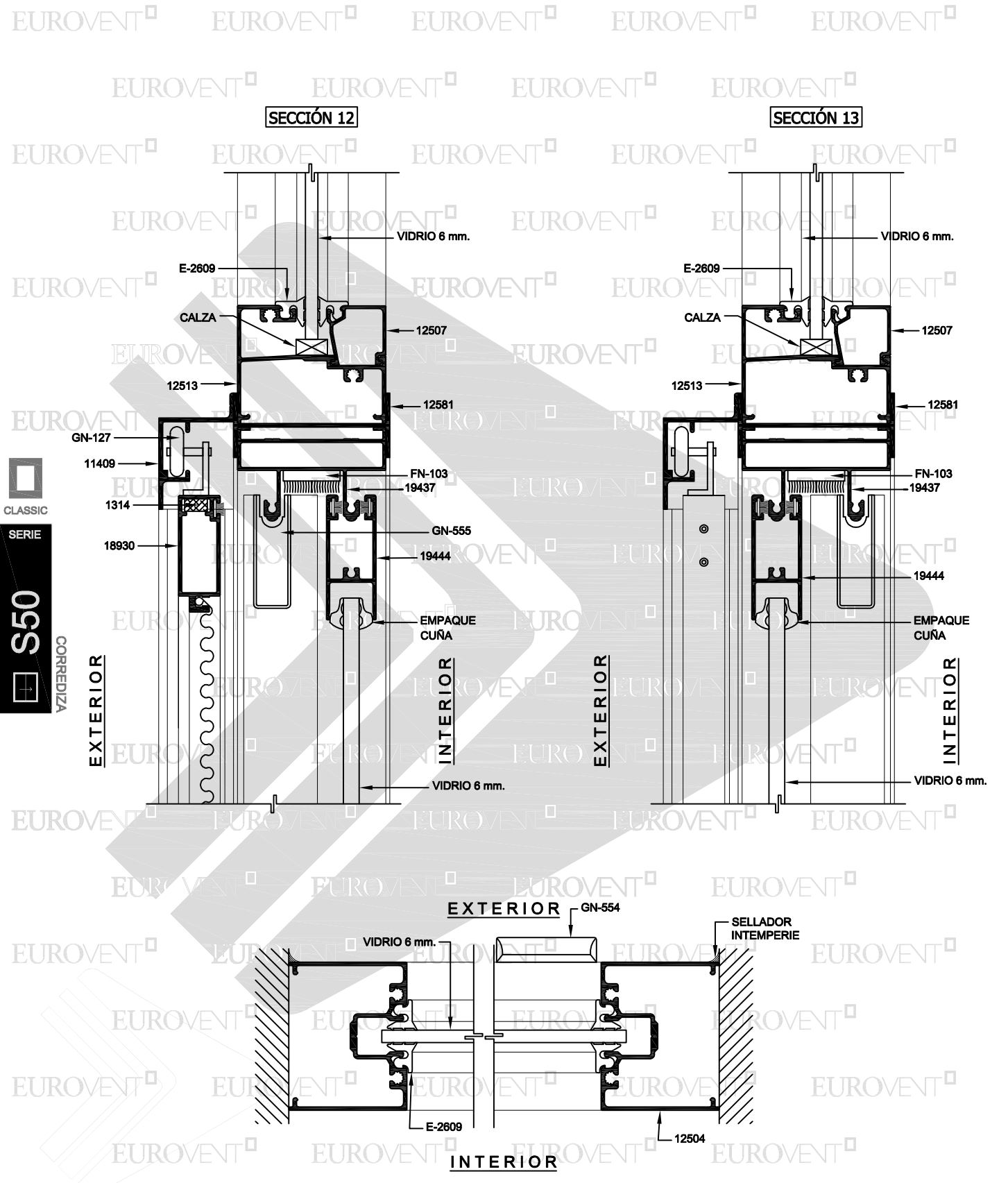

CLASSIC  
SERIE  
**S50**  
CORREDIZA

EUROVENT<sup>□</sup> EUROVENT<sup>□</sup> EUROVENT<sup>□</sup> EUROVENT<sup>□</sup> EUROVENT<sup>□</sup>

EUROVENT<sup>□</sup> EUROVENT<sup>□</sup> EUROVENT<sup>□</sup> EUROVENT<sup>□</sup> EUROVENT<sup>□</sup>

EUROVENT<sup>□</sup> EUROVENT<sup>□</sup> EUROVENT<sup>□</sup> EUROVENT<sup>□</sup> EUROVENT<sup>□</sup>

EUROVENT<sup>□</sup> EUROVENT<sup>□</sup> EUROVENT<sup>□</sup> EUROVENT<sup>□</sup> EUROVENT<sup>□</sup>

EUROVENT<sup>□</sup> EUROVENT<sup>□</sup> EUROVENT<sup>□</sup> EUROVENT<sup>□</sup> EUROVENT<sup>□</sup>

EUROVENT<sup>□</sup> EUROVENT<sup>□</sup> EUROVENT<sup>□</sup> EUROVENT<sup>□</sup> EUROVENT<sup>□</sup>

EUROVENT<sup>□</sup> EUROVENT<sup>□</sup> EUROVENT<sup>□</sup> EUROVENT<sup>□</sup> EUROVENT<sup>□</sup>

EUROVENT<sup>□</sup> EUROVENT<sup>□</sup> EUROVENT<sup>□</sup> EUROVENT<sup>□</sup> EUROVENT<sup>□</sup>

EUROVENT<sup>□</sup> EUROVENT<sup>□</sup> EUROVENT<sup>□</sup> EUROVENT<sup>□</sup> EUROVENT<sup>□</sup>

EUROVENT<sup>□</sup> EUROVENT<sup>□</sup> EUROVENT<sup>□</sup> EUROVENT<sup>□</sup> EUROVENT<sup>□</sup>

EUROVENT<sup>□</sup> EUROVENT<sup>□</sup> EUROVENT<sup>□</sup> EUROVENT<sup>□</sup> EUROVENT<sup>□</sup>

EUROVENT<sup>□</sup> EUROVENT<sup>□</sup> EUROVENT<sup>□</sup> EUROVENT<sup>□</sup> EUROVENT<sup>□</sup>

EUROVENT<sup>□</sup> EUROVENT<sup>□</sup> EUROVENT<sup>□</sup> EUROVENT<sup>□</sup> EUROVENT<sup>□</sup>

EUROVENT<sup>□</sup> EUROVENT<sup>□</sup> EUROVENT<sup>□</sup> EUROVENT<sup>□</sup> EUROVENT<sup>□</sup>

EUROVENT<sup>□</sup> EUROVENT<sup>□</sup> EUROVENT<sup>□</sup> EUROVENT<sup>□</sup> EUROVENT<sup>□</sup>

EUROVENT<sup>□</sup> EUROVENT<sup>□</sup> EUROVENT<sup>□</sup> EUROVENT<sup>□</sup> EUROVENT<sup>□</sup>

EUROVENT<sup>□</sup> EUROVENT<sup>□</sup> EUROVENT<sup>□</sup> EUROVENT<sup>□</sup> EUROVENT<sup>□</sup>

EUROVENT<sup>□</sup> EUROVENT<sup>□</sup> EUROVENT<sup>□</sup> EUROVENT<sup>□</sup> EUROVENT<sup>□</sup>

SECCIÓN 17

SECCIÓN 14

EXTERIOR

INTERIOR

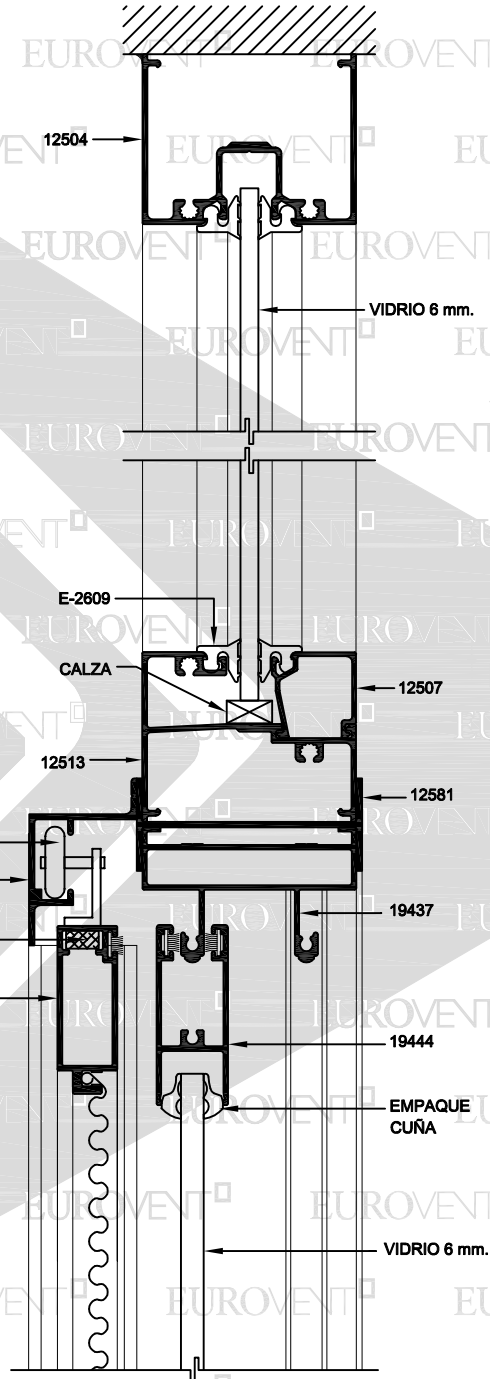

CLASSIC  
SERIE  
**S50**  
CORREDIZA

GN-508

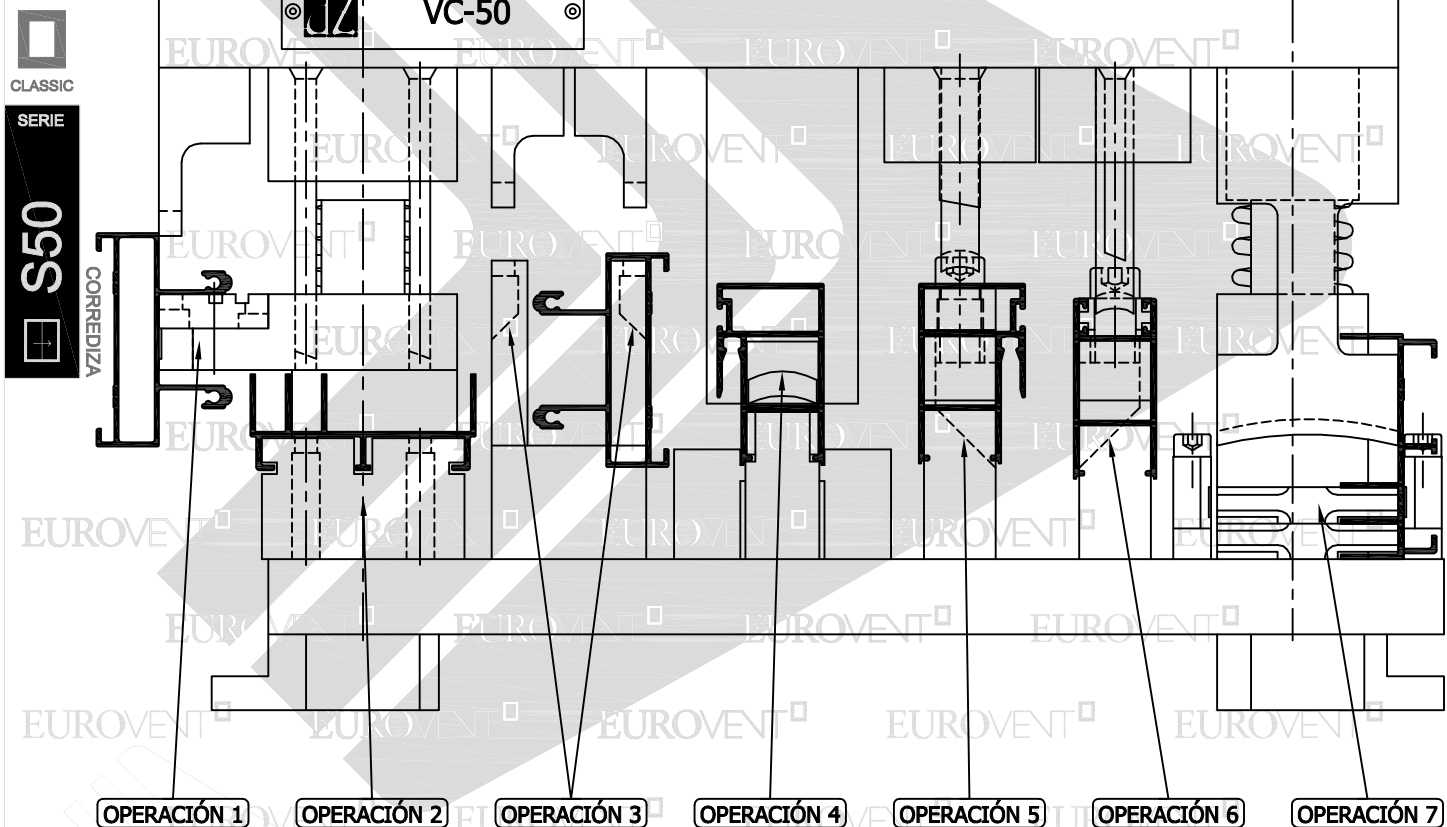



**OPERACIÓN 1**

19437 RIEL-CABEZAL  
19445 RIEL-CABEZAL BAJO  
19948 GUÍA INFERIOR  
DREN DE PISTA

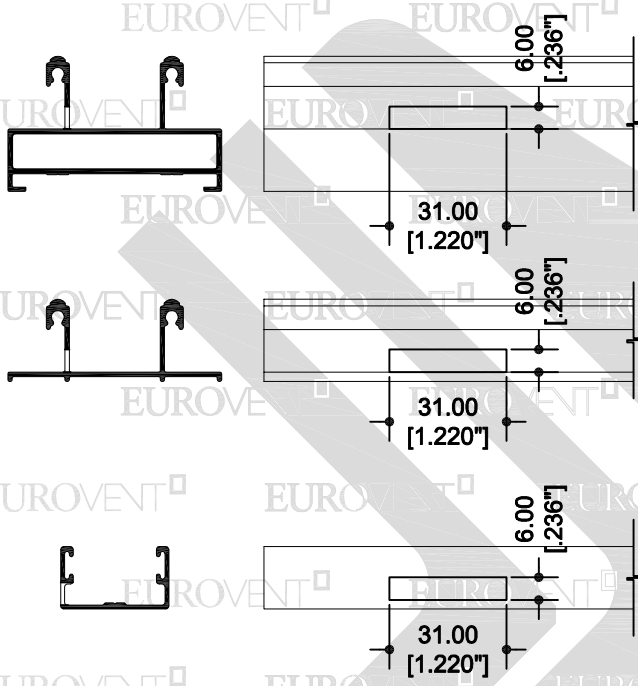

**OPERACIÓN 2**

19438 JAMBA  
BARRENOS

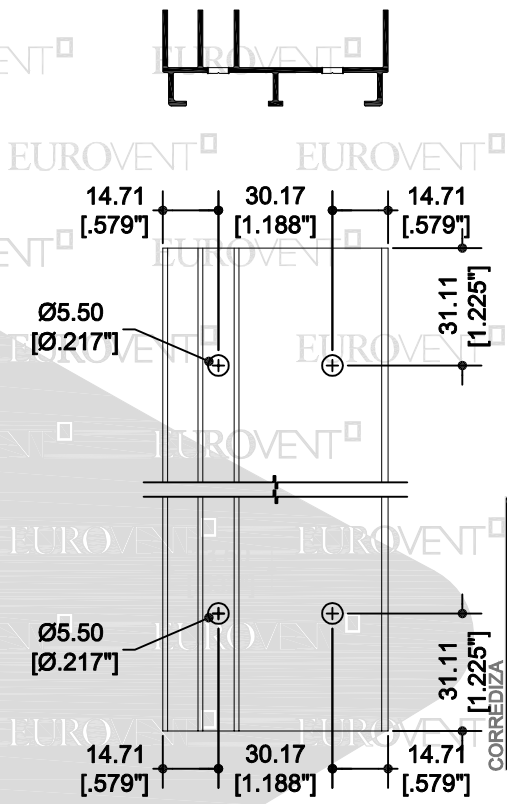

**OPERACIÓN 3**

19437 RIEL-CABEZAL  
DREN DE TUBULAR

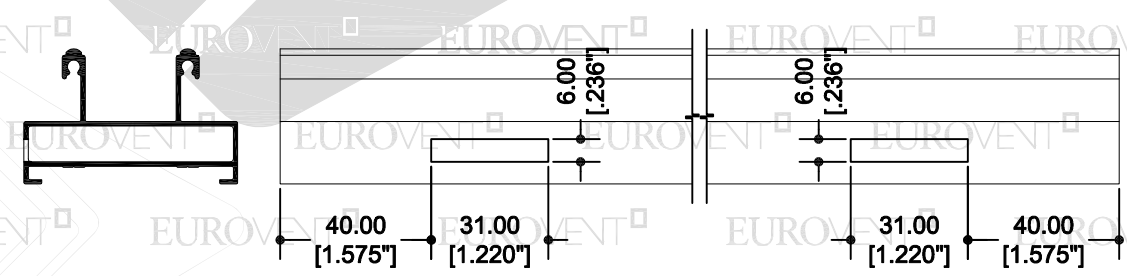

CLASSIC  
SERIE  
**S50**  
CORREDIZA

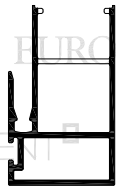

**OPERACIÓN 4**

19442 CERCO  
19443 TRASLAPE  
ENCASTRADO

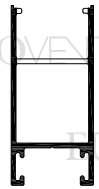

**OPERACIÓN 5**

19443 TRASLAPE  
GUÍA DE RIEL Y BARRENO

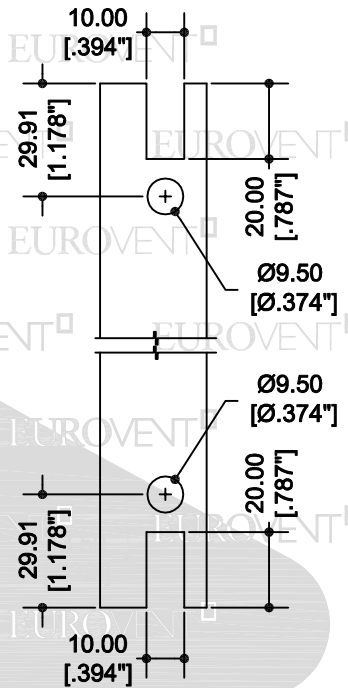
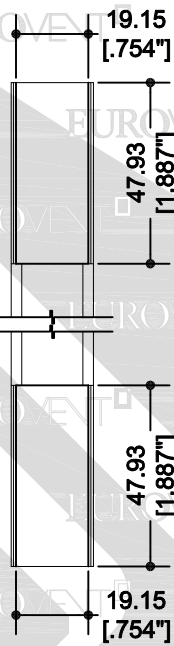
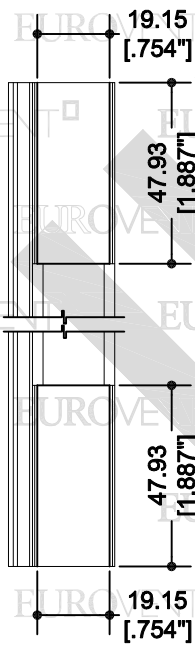
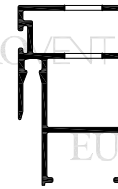

CLASSIC  
SERIE  
**S50**  
CORREDIZA



**OPERACIÓN 6**

19443 TRASLAPE  
BARRENO

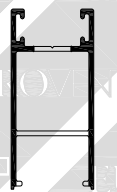

**OPERACIÓN 7**

19438 JAMBA  
ENCASTRADO

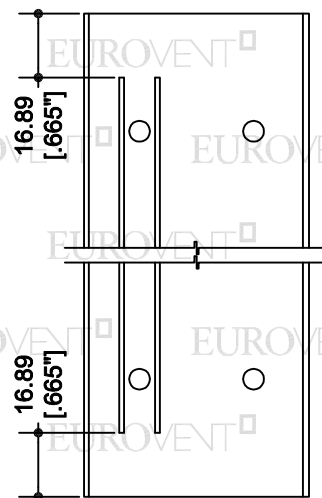
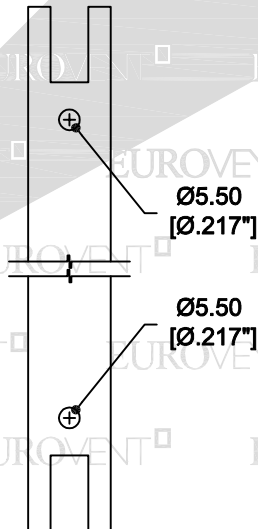
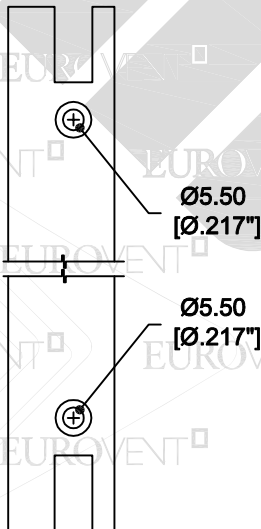
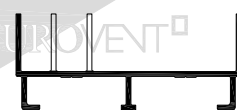

19442 CERCO  
CIERRE MINIBRIO

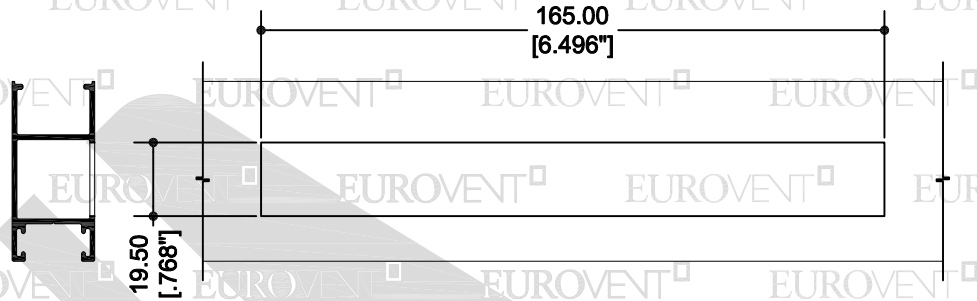

18930 MOSQUITTO  
UÑERO

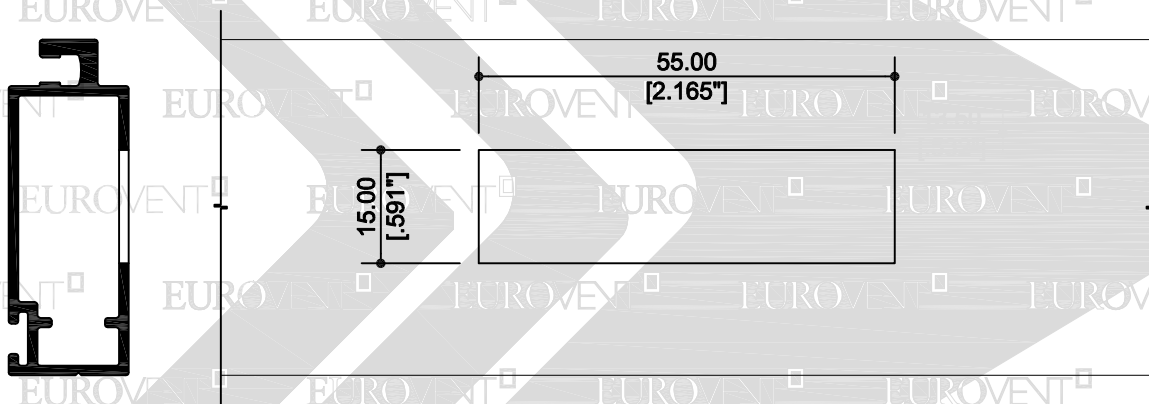

CLASSIC  
SERIE  
**S50**  
CORREDIZA

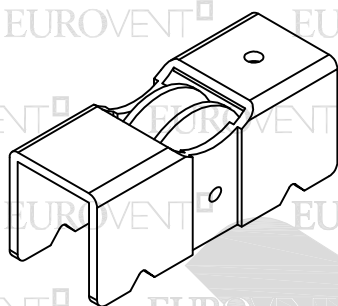

**GN-552**  
CARRETILLA FIJA



**GN-544**  
TAPA CERCO

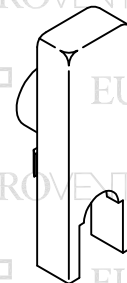

**GN-555**  
TAPA TRASLAPE

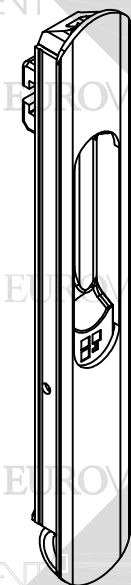

**GN-551**  
CIERRE MINIBRIO

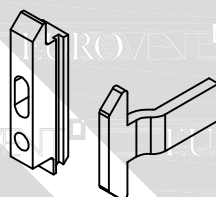

**GN-556**  
CONTRA Y GANCHO

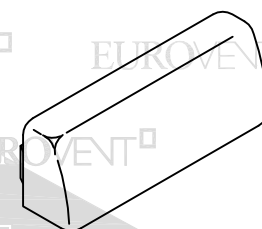

**GN-554**  
TAPA DREN



**GN-105**  
TAPÓN DESAGÜE

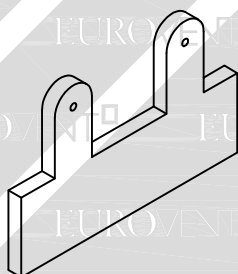

**EH-50**  
JUNTA DE HERMETICIDAD



**GN-155**  
UÑERO P/MOSQUITERO

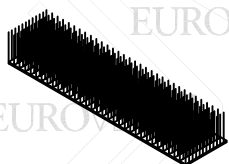

**FN-103**  
SELLO DE  
HERMETICIDAD

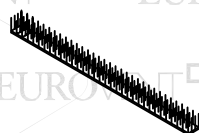

**FN-100**  
FELPA CON PLÁSTICO

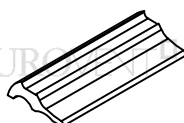

**VINIL CUÑA**

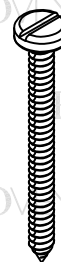

**PIJA**  
# 8 x 1"



**CALZA DE NEOPRENO**  
1/2" x 1/4"

CLASSIC  
SERIE  
**S50**  
CORREDIZA

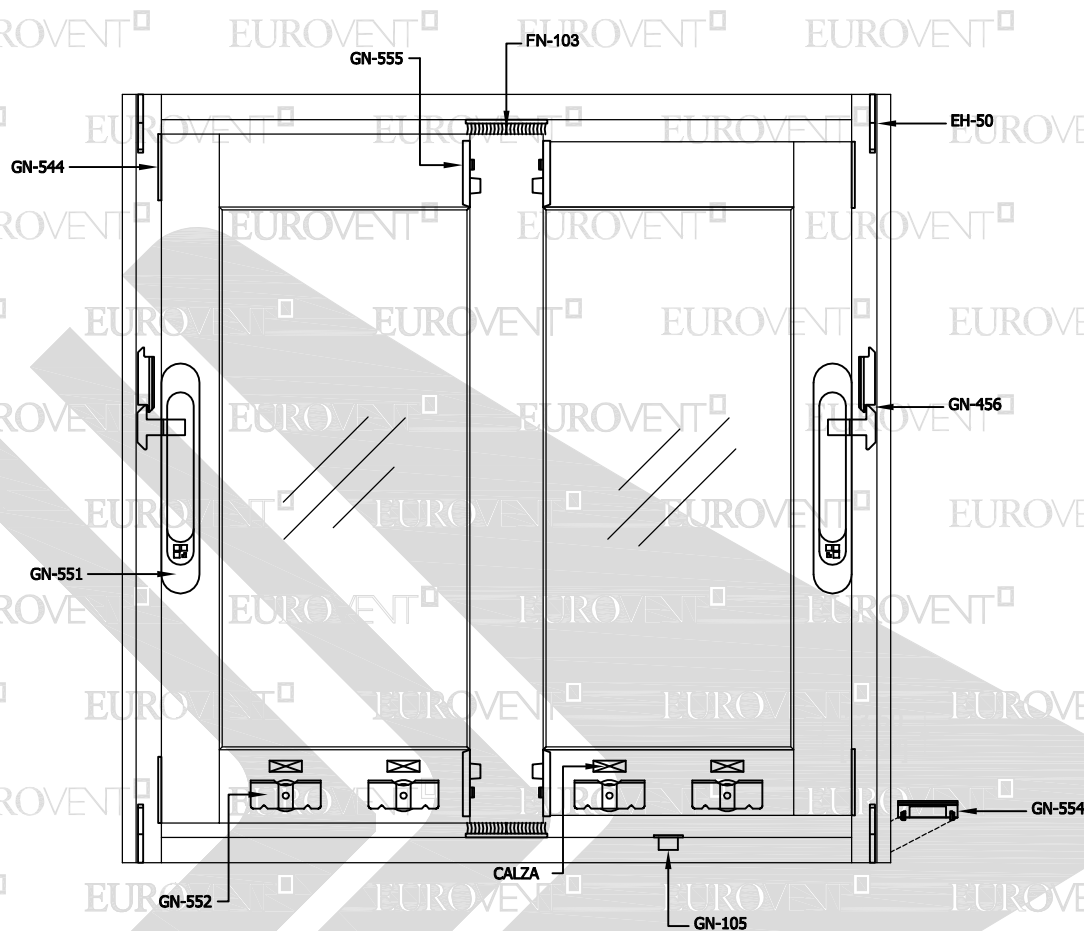
CLASSIC  
SERIECORREDIZA  
**S50**

CORREDIZA

**VENTANA CORREDIZA XX**

CLAVE	DESCRIPCIÓN	PIEZAS
FN-100	FELPA CON PLÁSTICO	-
FN-103	SELLO DE HERMETICIDAD	2
EH-50	JUNTA DE HERMETICIDAD	4
GN-105	TAPÓN DESAGÜE	1
GN-544	TAPA CERCO	4
GN-551	CIERRE MINIBRIO	2
GN-552	CARRETILLA ESTANDAR	4
GN-554	TAPA DREN CON VÁLVULA	2
GN-555	TAPA TRASLAPE	4
GN-556	CONTRA Y GANCHO	2

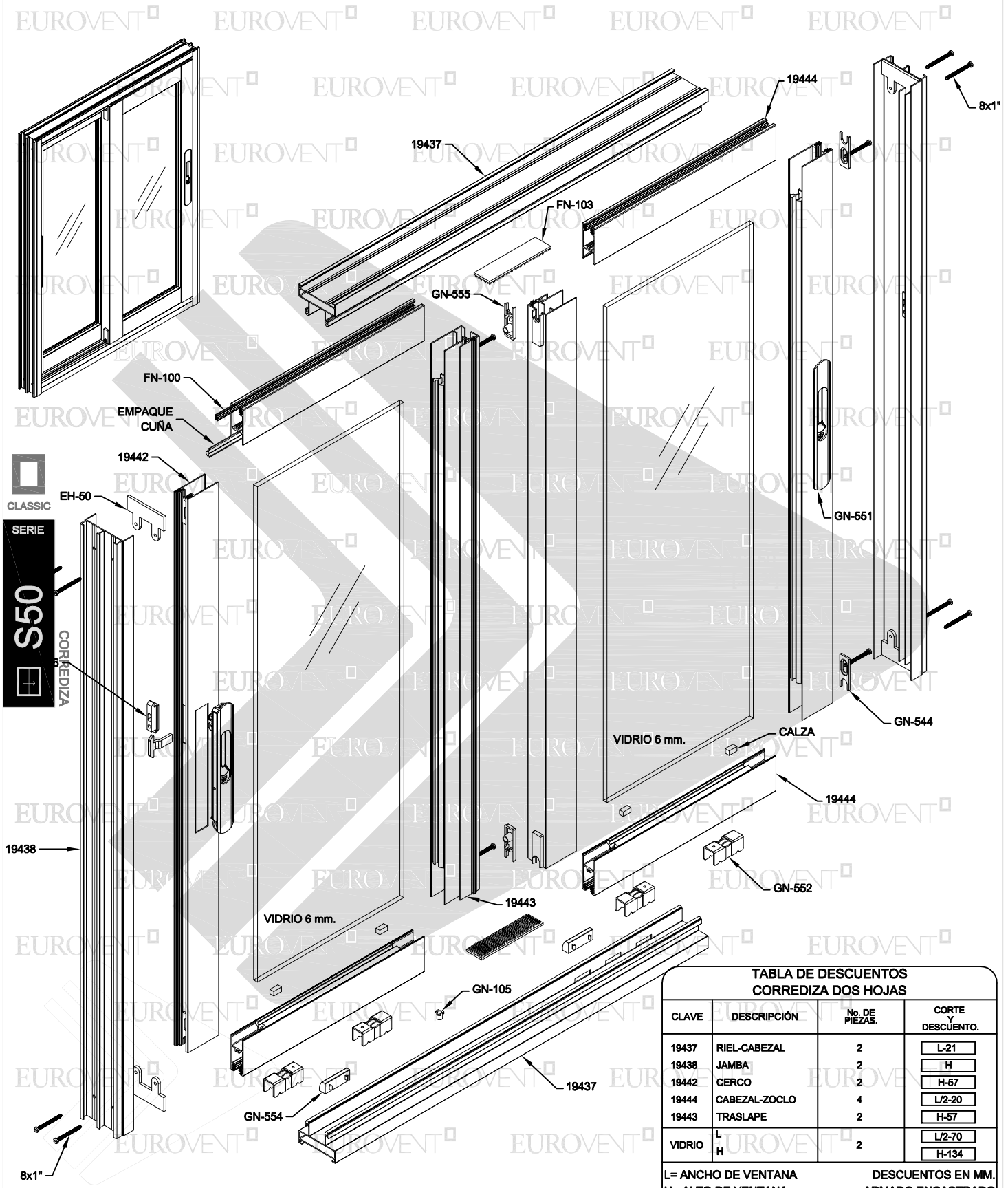

CLASSIC  
SERIE  
**S50**  
CORREDIZA

**TABLA DE DESCUENTOS  
CORREDIZA DOS HOJAS**

CLAVE	DESCRIPCIÓN	Nº DE PIEZAS.	CORTE Y DESCUENTO.
19437	RIEL-CABEZAL	2	L-21
19438	JAMBA	2	H
19442	CERCO	2	H-57
19444	CABEZAL-ZOCLO	4	L/2-20
19443	TRASLAPE	2	H-57
VIDRIO	L H	2	L/2-70 H-134

L= ANCHO DE VENTANA  
H= ALTO DE VENTANA

DESCUENTOS EN MM.  
ARMADO ENCASTRADO

DEFLEXIÓN MAX. L/175  
VENTANA CORREDIZA SERIE 50

LOS LÍMITES DE FABRICACIÓN PARA LOS PERFILES, SERÁN LOS QUE SE ENCUENTREN DEBAJO DE LAS CURVAS GRAFICADAS.

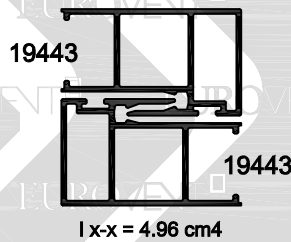
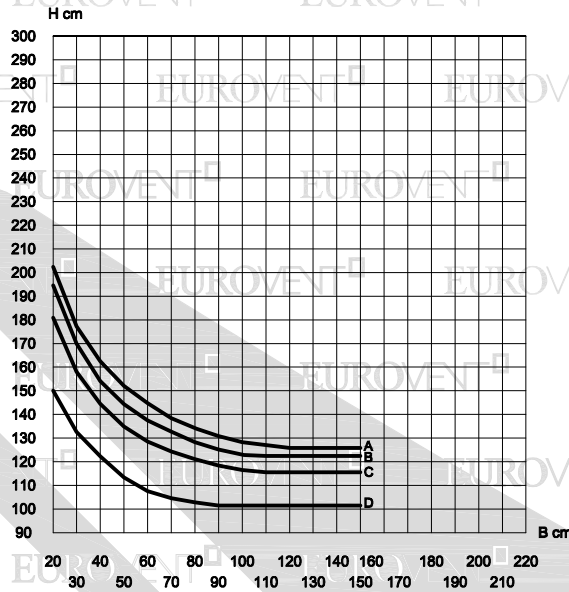

ALEACIÓN: 6063  
TEMPLE: 5

Valores de presión por velocidad de viento

Curvas	Presión del diseño	Velocidad de viento	Zona
A	45 Kg/m <sup>2</sup>	80 Km/h	Centro de grandes ciudades
B	50 Kg/m <sup>2</sup>	90 Km/h	Barrios Residenciales
C	65 Kg/m <sup>2</sup>	120 Km/h	Campo Abierto
D	110 Kg/m <sup>2</sup>	160 Km/h	Zona Costera

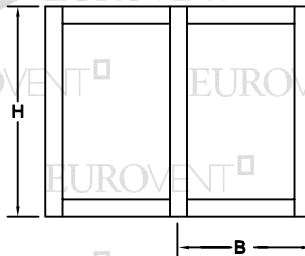

LOS LÍMITES DE UN CANCEL VAN EN FUNCIÓN DE LA COMBINACIÓN DE RESISTENCIA DEL PERFIL DE ALUMINIO, EL VIDRIO Y LOS ACCESORIOS QUE LO INTEGRAN.

VERIFICAR QUE LA DEFLEXIÓN DEL PERFIL SEA COMPATIBLE CON EL VIDRIO UTILIZADO.

CLASSIC  
SERIE  
CORREDIZA  
**S50**

## PARÁMETROS MÍNIMOS Y MÁXIMOS DE FABRICACIÓN.



VC-50  
MÍNIMO 0.40 x 0.40 HOJA  
MÁXIMO 1.50 x 1.80 HOJA



CLASSIC

SERIE

S50

CORREDIZA

## ALUMINIO

CLAVE	DESCRIPCIÓN	PIEZAS X ATADO	LARGO STD. MTS.	PERÍMETRO ANOD. CM.	PERÍMETRO PUL. CM.
11409	CABEZAL	12	6.10	18.30	7.30
12428	BOTAGUAS	28	6.10	9.99	8.18
18930	MOSQUITERO	10	6.10	14.14	10.68
19973	INTERMEDIO	4	6.10	17.59	6.85
19438	JAMBA	6	6.10	31.07	20.18
19442	CERCO	6	6.10	20.72	16.19
19443	TRASLAPE	6	6.10	22.50	17.04
19444	ZOCLO-CABEZAL	8	6.10	26.71	9.97
19948	GUÍA INFERIOR	16	6.10	14.33	11.50
19437	RIEL-CABEZAL	10	6.10	28.19	19.96
50701	ADAPTADPR OXXO	27	6.10	9.27	4.75